

CONTROL PANEL ACCESSORY KIT

INSTALLATION INSTRUCTIONS

Congratulations on your purchase of a new Control Panel Accessory kit. This kit was designed to provide inflation control of your air helper springs. This kit will be an asset to your vehicle, meeting nearly all of your air supply needs.

Please take a few minutes to read through the instructions, identify the components, and learn how to properly install your Control Panel Accessory kit.

NOTE:

The Control Panel Accessory kit can be used with all air helper spring products. If you are installing an air suspension system, do not install the air line tubing to the air springs as stated in the suspension system instruction manual. If you are adding the Control Panel Accessory kit to an existing air suspension system, you will need to deflate the air springs and remove the air line tubing.

NOTE ON CONNECTING THE AIR LINE TUBING:

Cut the air line tubing as squarely as possible. To connect the air line tubing to the fittings, push the tubing into the fittings as far as possible. If for any reason the tubing must be removed, first release the air pressure from the air helper spring. Push the collar toward the body of the fitting and the pull out the tubing. To reassemble, make sure the tubing is cut squarely and push the tubing back into the fitting.

Install the relay within three feet of the compressor. Nylon ties can be used to secure any excess wire and the relay neatly into place. Route the white wire labeled "Switch Panel" to the control panel. Connect the white wire to one of the white wires on the back of the switch. The remaining white wire will be grounded to the vehicle. Next, connect the orange wire labeled "Comp +" to the red (positive) wire on the compressor. Connect the red, fused wire labeled "Bat +" from the relay to the battery or another 12V (positive) source capable of supporting 20 amps. *See Figure "A".*

PARTS LIST

SINGLE AIR CONTROL PANEL	1
10 -32 x 1" MACHINE SCREW	2
10 -32 LOCK NUT	2
#10 FLAT WASHER	4
RING TERMINAL	1
WIRE CONNECTOR	2

TOOLS REQUIRED:

- 3/16" DRILL BIT
- POWER DRILL
- 3/8" DRILL BIT
- WIRE CRIMPER/STRIPPER
- PLIERS
- PHILLIPS SCREW DRIVER
- UTILITY KNIFE

Air Gauge Accessory Kit Installation Procedure

FIGURE "A"

Typical air line and wiring diagram for this kit. Note that air line and wire routing may vary depending on application.

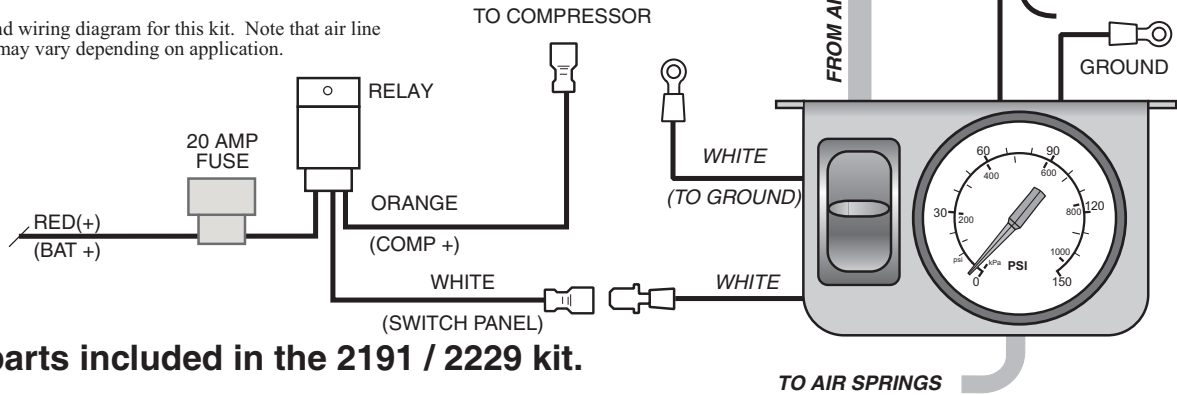

These parts included in the 2191 / 2229 kit.

FIGURE "B"

Install the control panel to the dashboard or selected mounting surface. Use the provided machine screws, lock nuts, and washers to attach the control panel to the dashboard.

Install the control panel after the electrical and air line connections have been made.

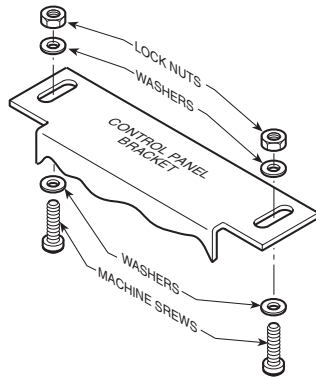
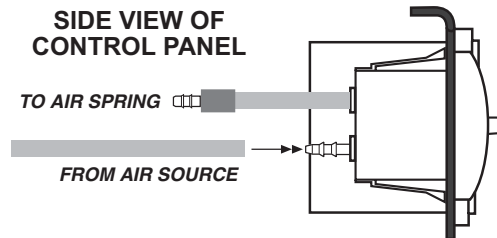

FIGURE "C"

Attach the air line tubing to the control panel as shown.

Soak the end of the air line tubing (1") in hot water for a few minutes to soften the tubing. Do not use pliers to work the tubing on to the barbed fittings, as the tubing may be damaged.



To inflate the air springs, hold the paddle switch up until the desired pressure is reached.

To deflate the air springs, push the paddle switch down.

FIGURE "D"

Install the wire connector as shown.

Slip the wire connector over the existing power wire and insert the unstripped connecting wire into the wire connector. Close the wire connector over the wires with pliers.

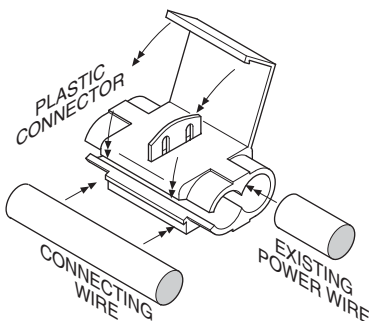

FIGURE "E"

Attach the control panel illumination wires as shown.

Attach the positive wire (red) to a dashboard illumination circuit. Attach the negative wire (black) to a suitable ground source on the vehicle.

Should additional wire be necessary, use 18 gage multi-strand wire.

