

## INSTALLATION INSTRUCTIONS

Congratulations on your purchase of a new Air Compressor Accessory Kit. This kit will be an asset to your vehicle, meeting nearly any of your air supply needs.

Please take a few minutes to read through the instructions, identify the components, and learn how to properly install your Air Compressor Accessory Kit.

### NOTE:

**THIS KIT IS NOT DESIGNED TO RUN AIR POWERED TOOLS. THE COMPRESSOR IS DESIGNED TO RUN AT A 20% DUTY CYCLE WITH A MAXIMUM RUN TIME OF 6 MINUTES. PLEASE ALLOW ADEQUATE TIME FOR THE COMPRESSOR TO COOL BETWEEN RUNNINGS.**

### NOTE ON CONNECTING AIR LINE TUBING:

Cut the air line tubing as square as possible. To connect the air line tubing to the fitting, push the tubing into the fitting as far as possible. If the tubing must be removed from the fitting, first release the air pressure from the system. Push the collar on the fitting toward the body of the fitting and pull out the tubing.

### TOOLS REQUIRED:

- UTILITY KNIFE
- PHILLIPS SCREW DRIVER
- WIRE CRIMPER/STRIPPER
- (2) 9/16" OPEN-END WRENCH
- CENTER PUNCH
- 3/8" DRILL BIT
- 11/16" DRILL BIT
- ELECTRIC DRILL
- 1/2" WRENCH
- 3/8" WRENCH

## PARTS LIST

COMPRESSOR	9335	1	3/8" FLAT WASHER	4
AIR TANK	9127	1	10 -32 x 1" MACHINE SCREW	3
PRESSURE SWITCH	9016	1	10 -32 NYLON-INSERT HEX NUT	3
COMPRESSOR T-FITTING	3066	1	3/16" FLAT WASHER	4
1/4" NPT PTC MALE FITTING		3	18 FT. AIR LINE TUBING	1
BULK HEAD FITTING		1	NYLON TIE	6
DRY COUPLER FITTING		1	15 FT. 14 GAGE WIRE	1
INFLATION GAUGE UNIT		1	WIRE CONNECTOR	1
25 FT. EXTENSION HOSE		1	FEMALE SPADE TERMINAL	1
3/8" -16 x 1" HEX BOLT		4	25 AMP BLADE FUSE	1
3/8" -16 FLANGED HEX NUT		4	FUSE HOLDER	1

# Auxiliary Air Inflation Kit

2239

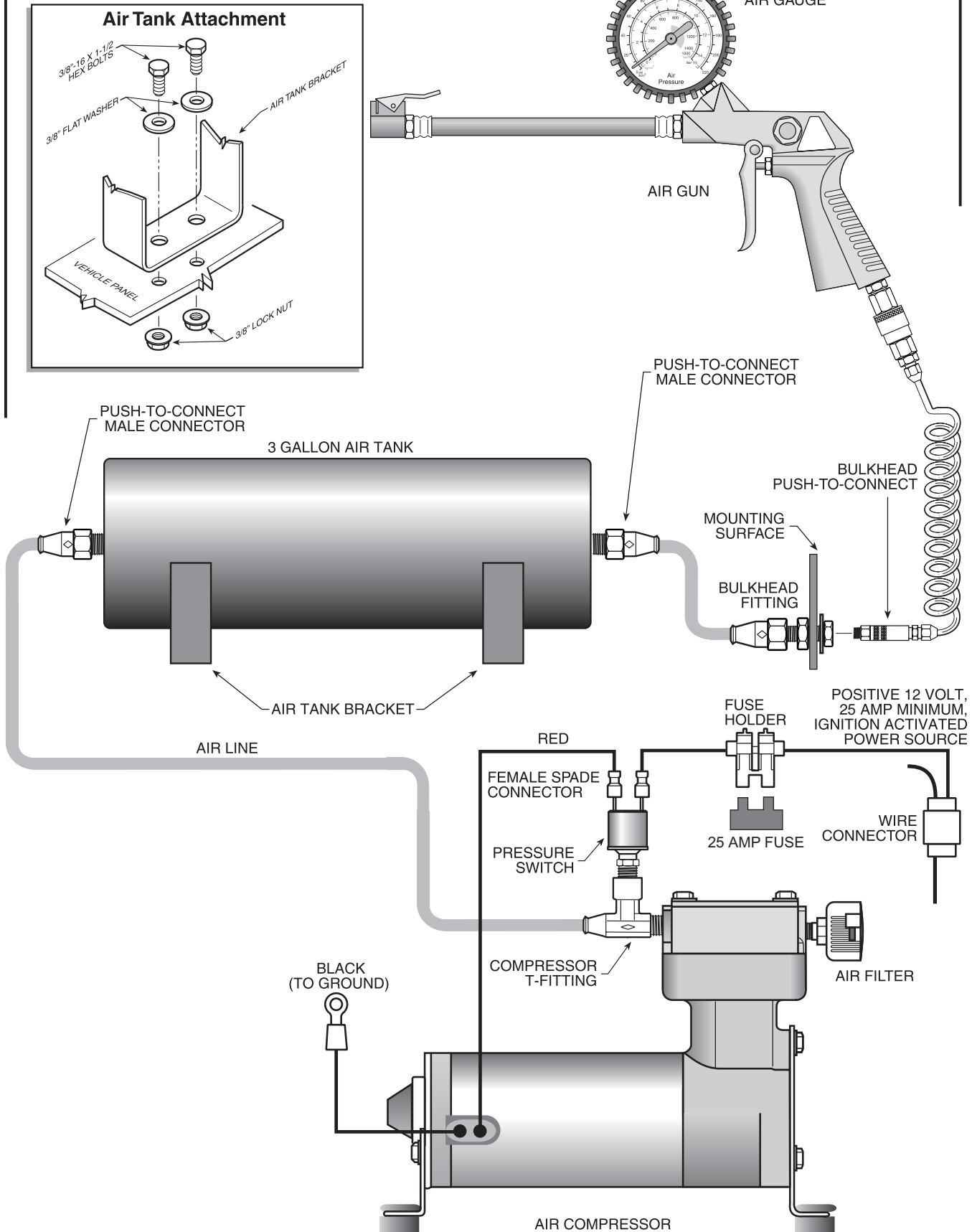
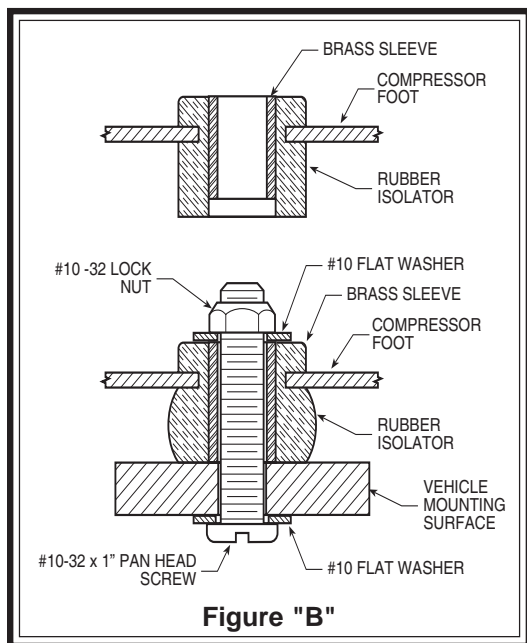

Figure "A"



**Figure "B"**

### **STEP 1 - PREPARE THE VEHICLE**

Remove the negative terminal on the battery.

### **STEP 2 - PREPARE THE COMPRESSOR**

Install the rubber isolator feet onto the compressor mounting brackets. Insert the brass sleeves into the top of the isolator feet, *see Figure "B"*. Install the compressor T-fitting into the threaded exhaust port on the compressor head, *see Figure "A"*. Tighten the fitting sufficiently to engage the pre-applied orange thread sealant. (Torque to 40 in. lbs.) **DO NOT OVERTIGHTEN THE FITTING.** Install the pressure switch into the compressor T-fitting. Install the air filter into the threaded inlet port on the compressor head (*finger tight*). Install the positive (red) wire from the compressor onto either spade on the pressure switch, *see Figure "A"*.

### **STEP 3 - MOUNT THE COMPRESSOR**

Select a convenient location to mount the compressor. This location should provide ample air flow and be protected from airborne debris and moisture. The mounting surface should be rigid to support the compressor, such as under the hood on a fender well or in a vented storage compartment. The compressor is oil-less and can be mounted in any orientation necessary for installation.

Using the compressor as a template, center punch, and drill three 3/16" holes. Before drilling, ensure that there are no electrical, fuel, or brake lines on the opposite side of the mounting surface that can be damaged by the drill. Any burrs in the holes should be removed to prevent damage to the rubber isolators. Mount the compressor using the supplied 10-32 x 1" machine screws, 10-32 lock nuts, and 3/16" washers. *See Figure "B"*. Maximum vibration isolation can be achieved by properly mounting the compressor. The machine screw and nut should be tightened only enough to bottom-out the brass insert, *see Figure "B"*. **DO NOT OVERTIGHTEN.** Overtightening will crush the brass insert and the rubber isolator, thereby reducing vibration isolation.

Attach the black wire from the compressor to a grounded component of the vehicle's chassis.

### **STEP 4 - MOUNT THE AIR TANK**

Install the male push-to-connect fittings into both ports on the air tank. Tighten the fitting sufficiently to engage the pre-applied orange thread sealant. Select a location to mount the air tank. This should be a protected location to prevent damage from flying rocks or debris. Using the holes in the tank brackets as a template, mark the locations of the mounting holes on the mounting surface. Use a center punch to mark the center of the holes on the mounting surface. Before drilling, ensure that there are no electrical, fuel, or brake lines on the opposite side of the mounting surface that can be damaged by the drill. Drill four 7/16" holes on the center marks. Using the supplied 3/8" hex bolts and flanged hex nuts, attach the air tank in to the mounting surface. *See Figure "A"*. Ensure clear access to the fittings on the air tank is maintained. *Do not exceed 120 psi in the tank.*

### **STEP 5 - MOUNT BULK HEAD FITTING**

Install the bulk head fitting in a convenient protected location. The location could be any rigid flat surface that would be accessible for easy discharge of air for the end user. Before drilling, ensure that there are no electrical, fuel, or brake lines on the opposite side of the mounting surface that can be damaged by the drill. Mark and drill a 1 1/16" hole in the desired location. Install the bulk head fitting and tighten, *see Figure "E"*. Install the 1/4 NPT fitting on the compressor side of the bulk head fitting and tighten the fitting sufficiently to engage the pre-applied thread sealant. Install the dry coupler fitting on the other side of the bulk head fitting and tighten the fitting sufficiently to engage the pre-applied sealant.

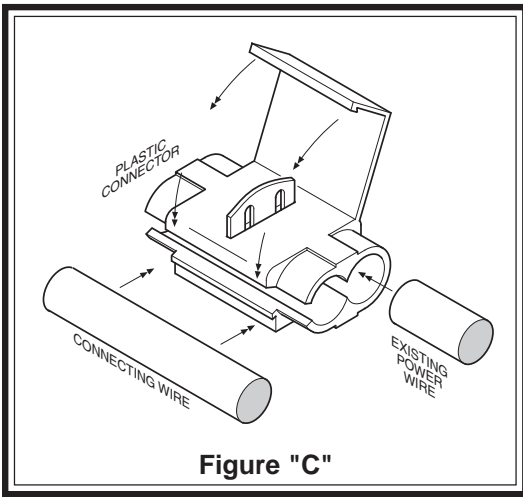

**STEP 6 - ROUTE THE AIR LINE TUBING**

Route a length of air line tubing from the push-to-connect fitting on the air tank to the T-fitting on the compressor. *See Figure "A"*. Route a length of the airline tubing from the tank to the bulk head fitting, *see Figure "A"*. Route the air line to avoid sharp edges or heat from the engine or exhaust system. Using a razor knife, make the cut as square as possible and push the air line into the fittings as far as possible. *Do not fold or kink the air line tubing.*

**STEP 7 - WIRE THE SYSTEM**

Strip 1/4" off the end of the red 14 gage wire supplied with the kit. Crimp a female spade connector onto the end of the red wire. Install the female spade connector onto the remaining spade on the pressure switch. Using a wire connector, attach the opposite end of the wire to an ignition activated, positive 12 Volt, 25 Amp minimum power source. *Consult the manufacturer's wiring diagram for your vehicle.* Slip the wire connector over the existing ignition activated wire and insert the un-stripped 14 gage wire into the connector. Close the wire connector over the wires with pliers, *see Figure "C"*.

Install an in-line fuse in the 14 gage power wire, as close to the power source as conveniently possible. Cut the 14 gage wire and insert the un-stripped ends into the fuse holder. Close the fuse holder with pliers and insert a 25 Amp blade fuse. *See Figure "D"*.

NOTE: Should additional wire be necessary, 14 gage multistrand wire may be used.

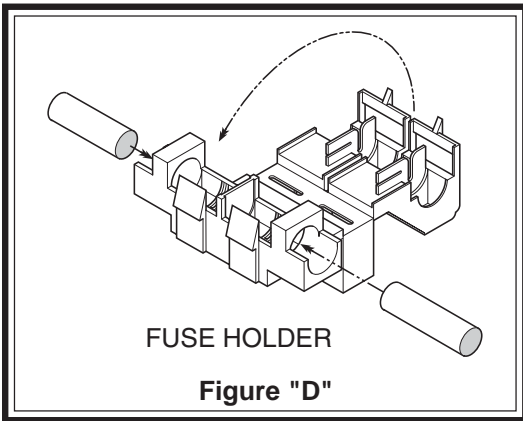

**STEP 8 - TEST THE SYSTEM**

Re-attach the negative terminal on the battery. Turn on the vehicle's ignition. The air compressor will run for a short time to build pressure in the tank. Once the pressure reaches 120 psi in the air tank, the pressure switch will turn the compressor off. It will not restart until the pressure in the tank drops below 90 psi.

**USING THE AIR COMPRESSOR ACCESSORY KIT**

Your system is now ready to use. With the coiled tubing provided, attach the end with the coupler fitting to the bulk-head fitting. Install the coupler fitting on the gauge unit then attach the gauge unit to the coiled tubing. You can now use the air chuck gauge unit for inflation.

**FILTER MAINTENANCE**

It is recommended that the air compressor filter be inspected periodically. If the filter is sufficiently clogged with road debris or moisture, it will require replacement.

